



**PERFORM  
BETTER**

# Let visions become reality: Experience meets passion

Following the philosophy „Turning visions into reality“, we use our extensive experience as a resource to realize ideas together. Whether it's a gym, a physiotherapy practice, a personal training studio or an athletics center - with over 10 years of expertise, we are ready to provide you with targeted support. Thanks to our many years of experience in functional and athletic training and our partnerships with first-class brands, we have become experts in the world of studio design.

We create customized solutions - from planning to installation - that are specifically designed for your individual needs and location. However, our service goes beyond simple realization: we offer continuous support through consulting, training and expertise in the areas of digitalization and marketing. Together with you, we make your dreams come true.

Our profound expertise and our passion for training and health make us a trustworthy partner for you if you want to pursue your goals.



Marco Schubert  
CEO



Mükremin Bingöl  
Head of Sales



**PERFORM  
BETTER**





## Studio Design

**In 5 steps to your vision |** With our full-service offer, we are at your side in all phases - from planning, delivery and installation through to maintenance. Even after the project has been completed, we offer you continuous support and are always there for you.



## PB Gym

**The all-in-one Masterstudio |** Our Masterstudio covers all aspects of functional training, whether you prefer a specific zone or the complete package. From the floor, turf, racks and small equipment to recovery tools, we offer individual training areas.



## PB Physio

**The all-in-one sample studio for your medical practice |** We offer the ideal room and furnishing concept for every step, be it new planning, renovation or modernization. Because we know: The more individual your patients' needs are, the more important the right equipment becomes.

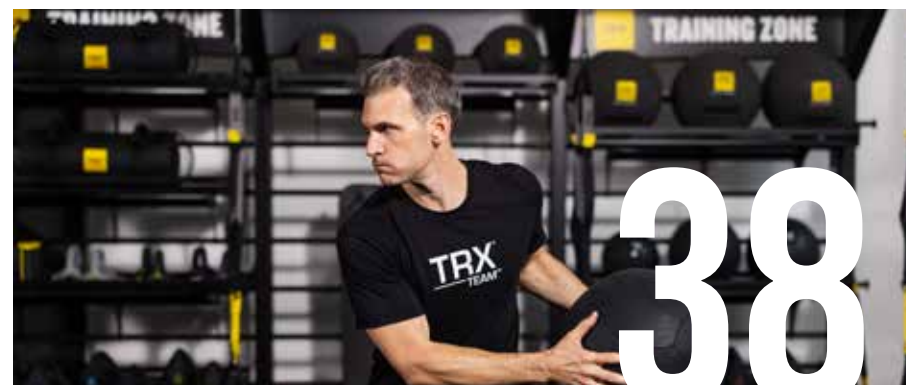

## TRX Studioline

**Effective training in an inspiring environment |** With TRX® studio solutions, you can make optimum use of the space and create an individual functional training zone with an attractive design. Your customers will be impressed by the high-quality materials and sophisticated systems!



## CENTR x HYROX

**Ready for the next HYROX challenge?** Discover the new performance line from CENTR x HYROX for your own gym. With the same equipment as for official competitions, you and your clients will be optimally prepared to increase performance.



## PB Steel

**Discover our high-quality steel products** | Fully customizable rigs, racks, attachments and multistorage solutions for home gyms, gyms, fitness studios, performance centers and physiotherapy practices. Robust and premium quality.



## The right solution

We face unique challenges with every project, as the equipment requirements vary depending on the area and use. Thanks to our extensive expertise and broad product range, we are able to equip every room individually.



## In-house training

Through our in-house training courses, you can ensure that your employees in your studio/practice are continuously developing new skills and learning to meet the challenges of a changing world of work.

# Let your visions become reality with us!

We don't just want to realize a project, we want to build a long-term partnership. That's why we're with you every step of the way: Our journey starts with a face-to-face meeting, a video call or a phone call to discuss your vision.

We systematically plan your training environment, including flooring and equipment, with 3D designs for visualization. A customized offer is created according to your requirements. Detailed production planning and preparation take place, followed by delivery, flooring and precise installation.

**+200.000**

Customers made satisfied

**+180.000**

sqm floor laid

**+8.500**

Trainer educated

**+5.000**

Studios furnished

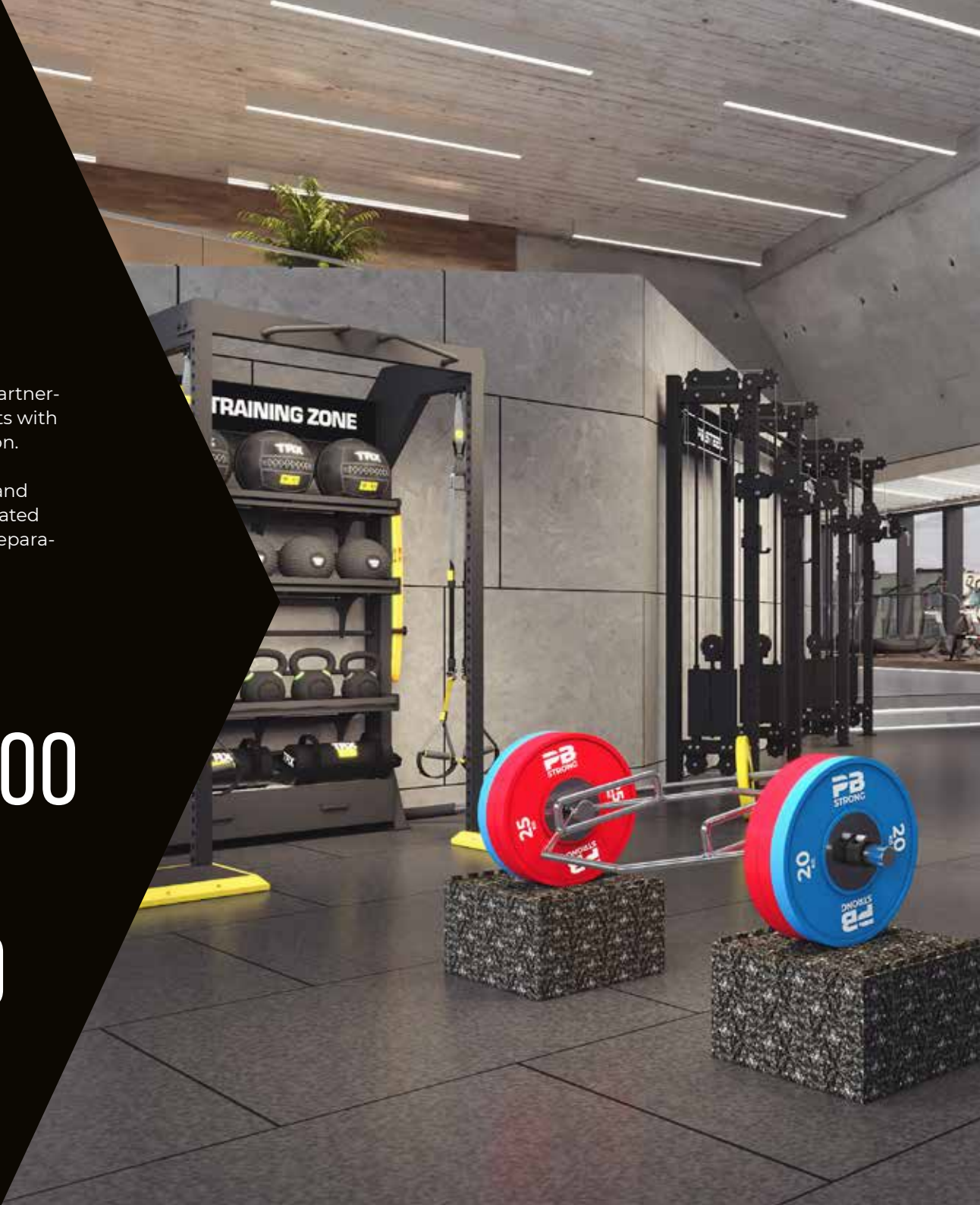

# In 5 steps to your vision



## 1.

### GETTING TO KNOW

The first step of our journey together can either be a personal meeting, a video call/online meeting or by telephone. This gives us the opportunity to get to know each other better and talk about your wishes and visions. We focus on the details of your property or training area to create a clear base for our planning.

## 2.

### CONCEPT & DESIGN

We take a systematic approach, starting with the design of your flooring and the planning of rigs, racks, cable pulls and cardio equipment to create a complete training experience. We also consider kettlebells, dumbbells and barbells as well as TRX systems and sleds. Our process includes 3D designs that give you a clear vision. These designs help to optimize each element before implementation begins. So your vision will be perfectly realized.

## 3.

### FINALIZATION

After discussing your wishes and requirements, we will create a customized offer that takes possible changes into account. (Only when the quote meets your expectations do we commission the implementation). We then plan the production in detail, from floor coverings to constructions such as rigs. Our experts ensure precise planning for a smooth implementation. Your studio takes shape as we carefully prepare each component to turn your vision into reality.

## 4.

### IMPLEMENTATION

The next step involves the delivery and unloading of the products. This is particularly relevant when our team is responsible for installation. After careful preparation of the subfloor, we lay the floor. This is followed by the precise installation of the training and storage systems with the utmost care. Every detail is considered to ensure that your studio is both functional and aesthetically pleasing and meets the highest standards.

## 5.

### SUPPORT

Following successful implementation, our commitment continues beyond the end of the project. We will continue to be there for you and offer ongoing support. If questions arise or you would like targeted further training, we organize in-house training courses with renowned experts. We also support you with topics such as digitalization and marketing. Our experience is your resource for realizing your visions and promoting sustainable success.

# ALL-IN-ONE Masterstudio

The All-in-One Masterstudio (PB Gym) covers the entire spectrum of functional training. Whether you want to focus on a specific zone or prefer the whole package, you'll find everything here - from mobility and recovery to athletics, cardio, strength and coordination. Our all-inclusive training environments are the ideal solution for individual training goals.



**PERFORM  
BETTER**



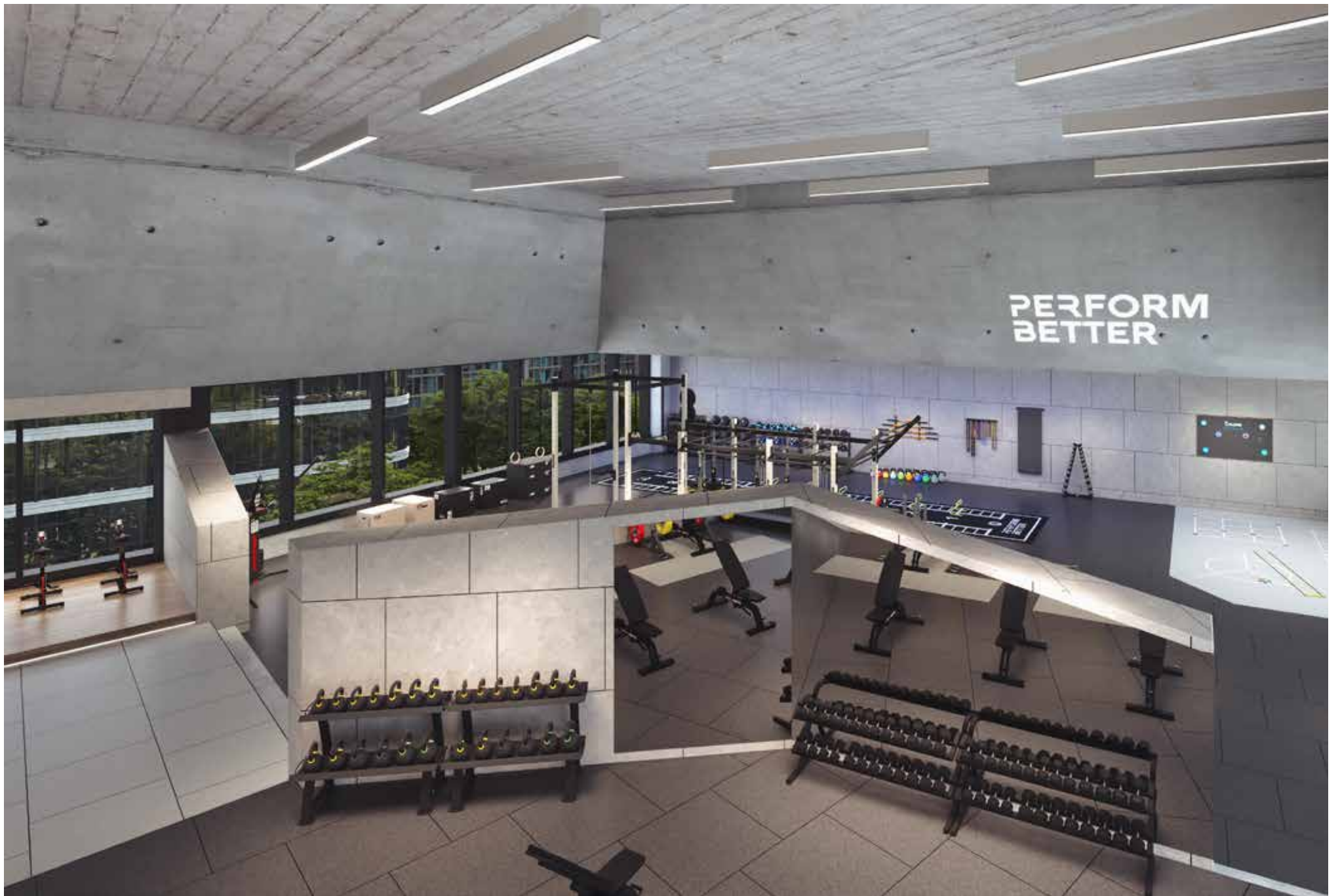

# Flooring



## Standard

### Specifications

- Flat  
11 mm, 15 mm, 20 mm, 30 mm
- Anti-shock  
43 mm, 53 mm, 63 mm

### Benefits

- High density
- Made in Europe
- 100% recycled rubber
- Odorless

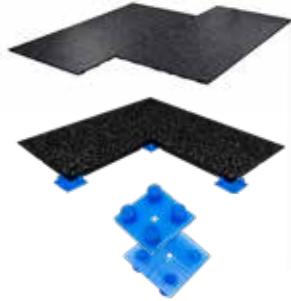

## Connect

### Specifications

- 20 mm thickness
- 30 mm thickness
- 40 mm thickness

### Benefits

- Easy to clean
- Easy to install
- Comprehensive 5-year warranty
- Acoustic quality



## Rollware

### Specifications

- From 4 mm up to 14 mm in 2 mm increments
- Standard roll width is 1.25 meters

### Benefits

- High density
- Made in Europe
- 100% recycled rubber
- Odorless



## Outdoor

### Specifications

- All outdoor fitness slabs are 1 x 1 meter in size. They are available in thicknesses of 30 and 43 mm.

### Benefits

- High density
- Made in Europe
- 100% recycled rubber
- For outdoor use

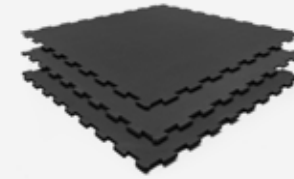

## Puzzles

### Specifications

- From 6 mm, home training
- From 8 mm, functional zones
- From 10 mm, functional zones
- 60 x 60 cm & 100 x 100 cm

### Benefits

- Interlocking Puzzle System
- Made in Europe
- 100% recycled rubber
- Odorless



## Vinyl floor

### Specifications

- XL planks 1.5 meters and XL tiles 1 meter x 1 meter
- Crystal wear layer
- High resolution design

### Benefits

- 100 % range, phthalate-free, formaldehyde-free
- TVOC < 10 micrograms / m3: best indoor air quality

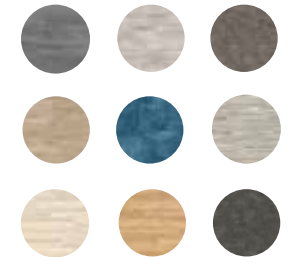

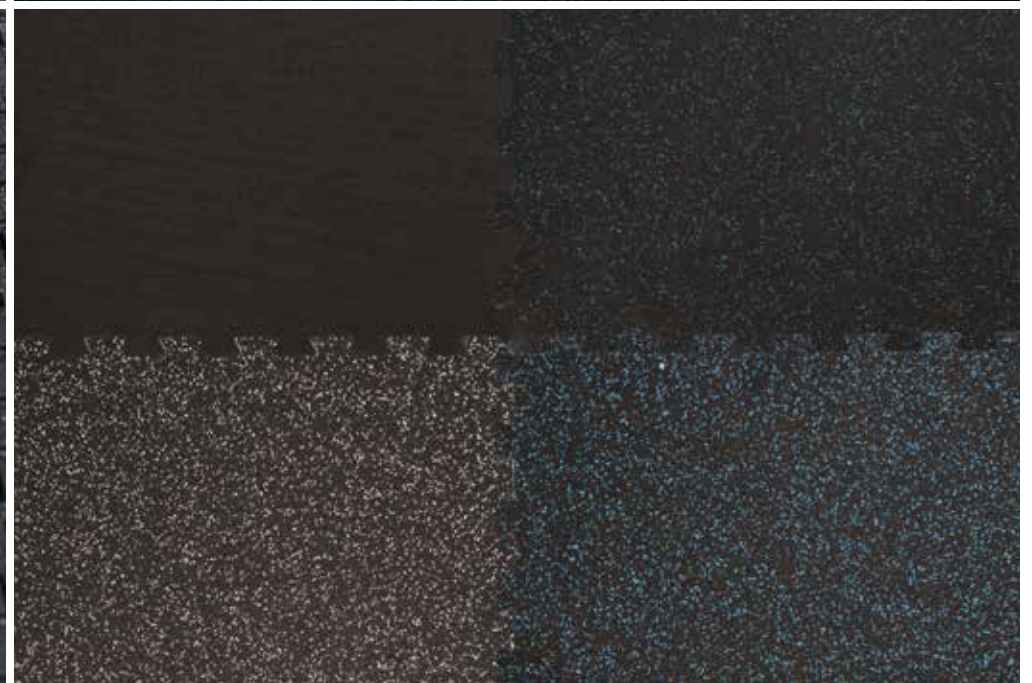

# Turf

- 100% polyethylene pile with a latex backing.
- Short-pile artificial turf for crossfit and fitness training.
- Colored markings and numbers. High-density turf, consists of over 80,000 fibers per sqm.

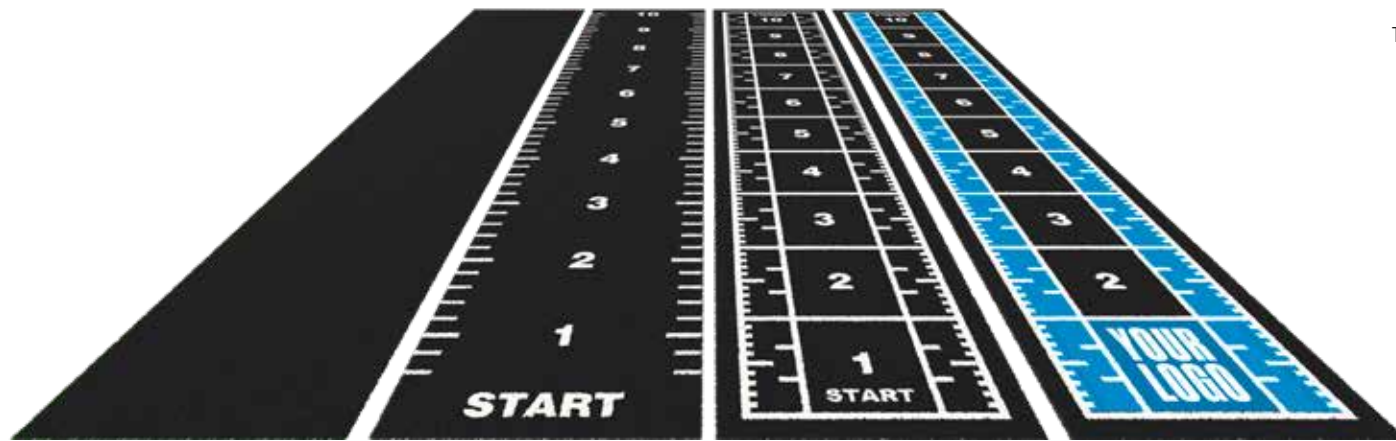

UNI RANGE

ESSENTIAL RANGE

PREMIUM RANGE

CUSTOM TURF

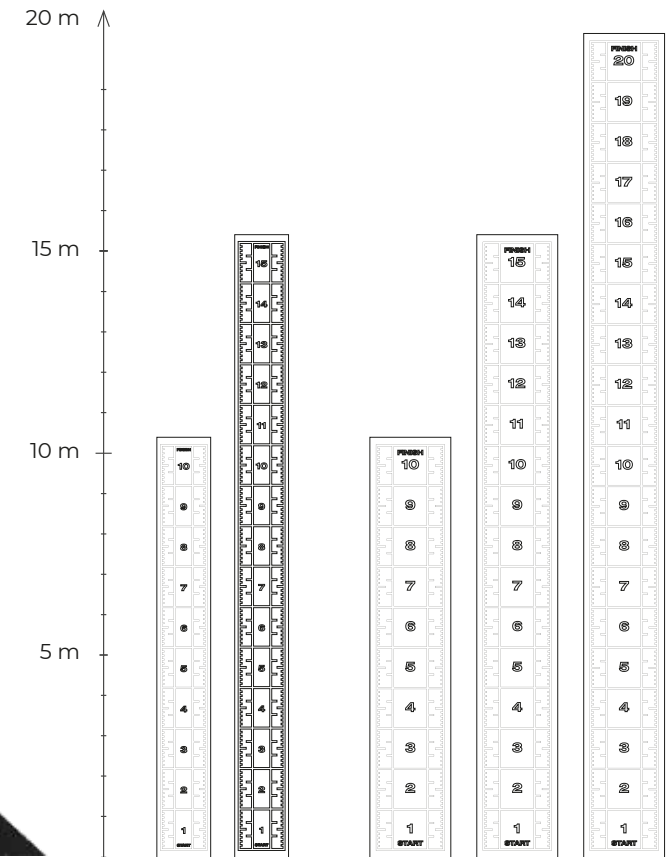

Width 1.33 m

Width 2 m





# Cardio



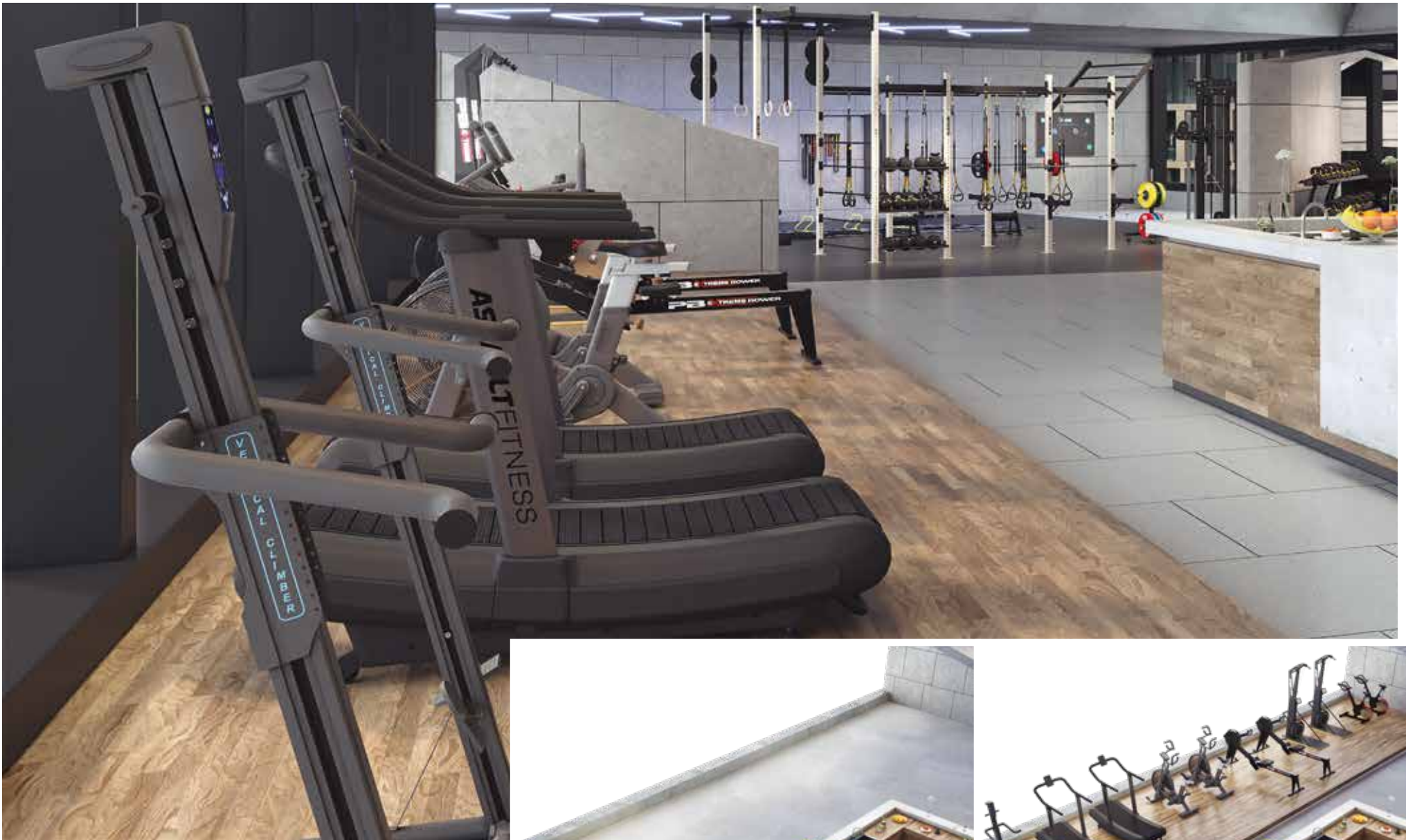

# Functional

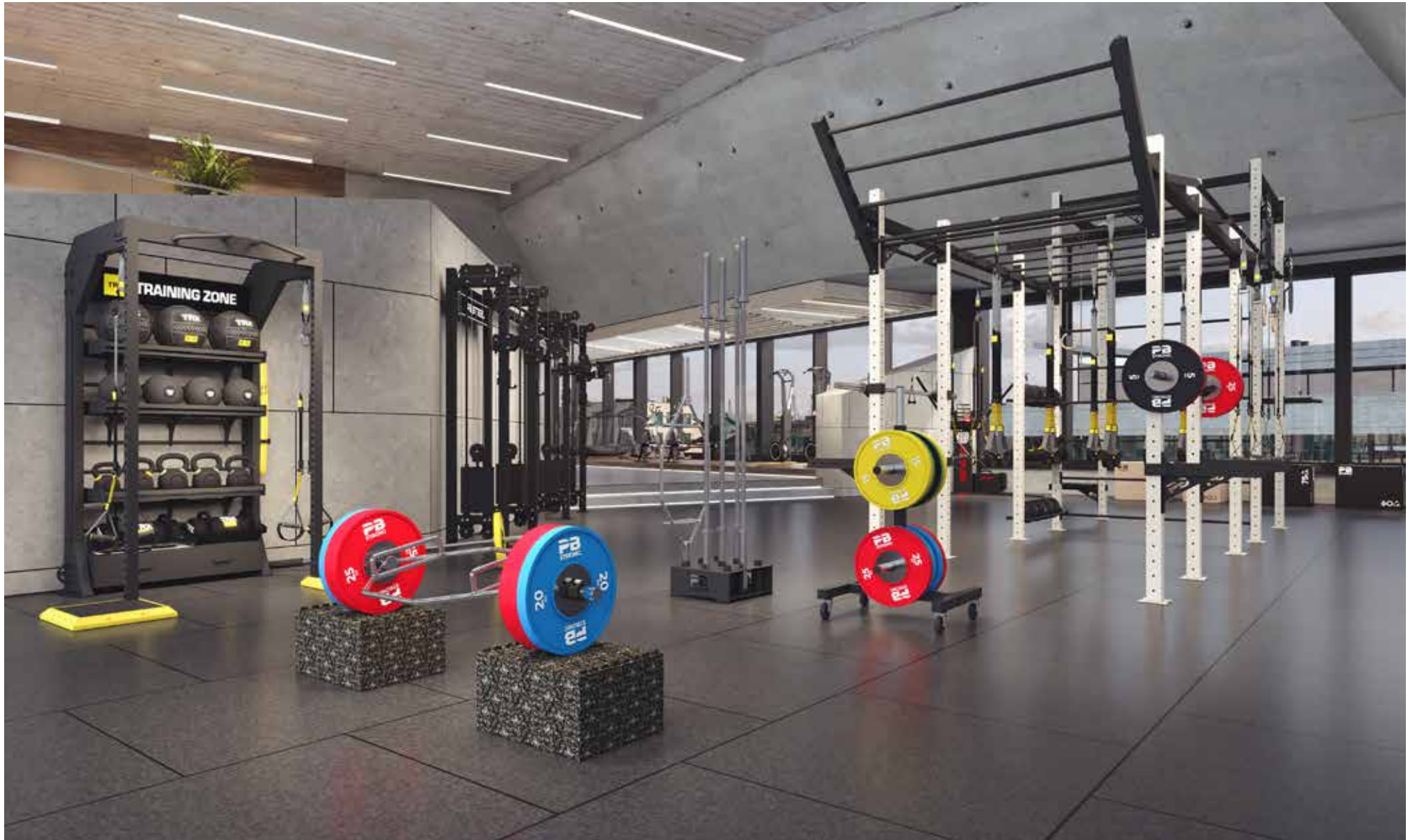





# Athletic | Performance



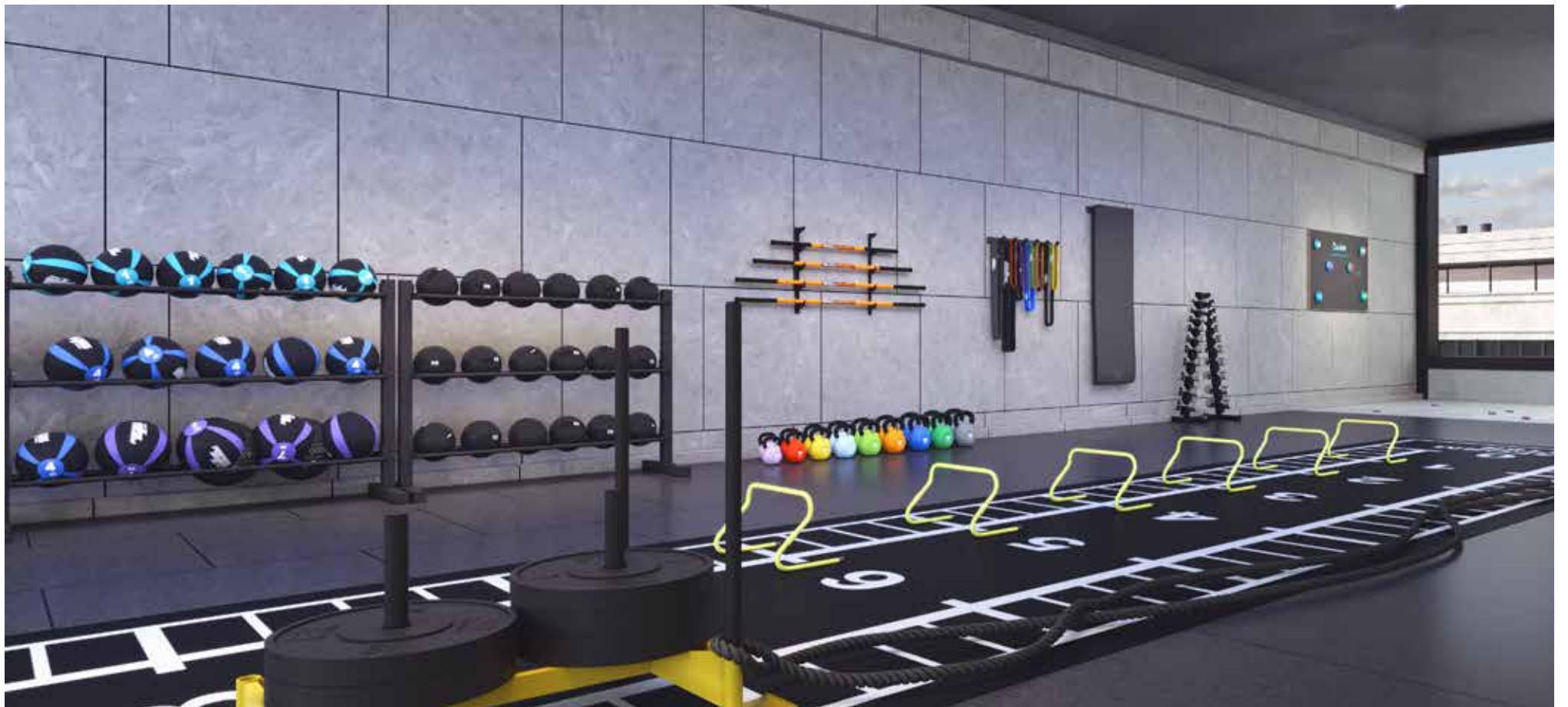

# Strength





# Reaction





# Group Fitness





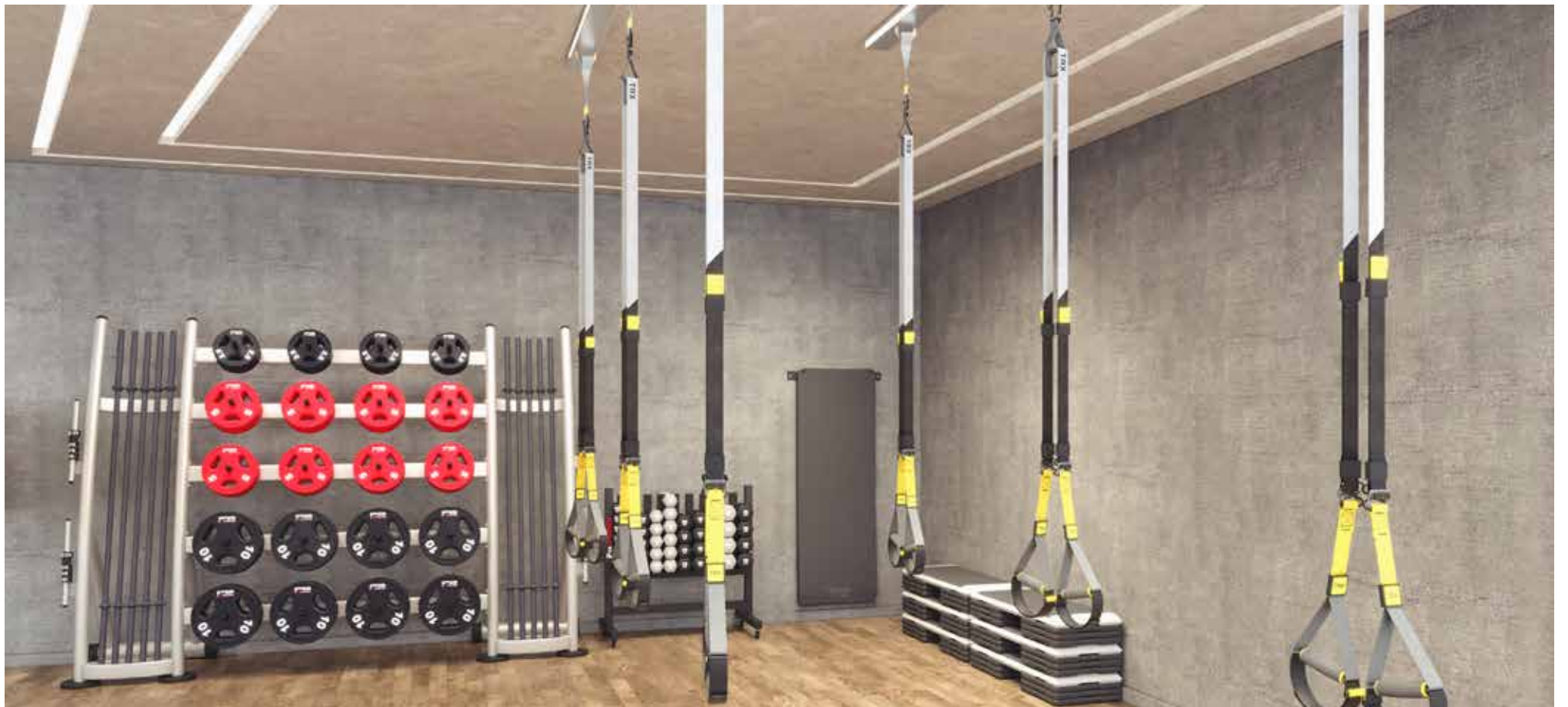

# Area | Recovery

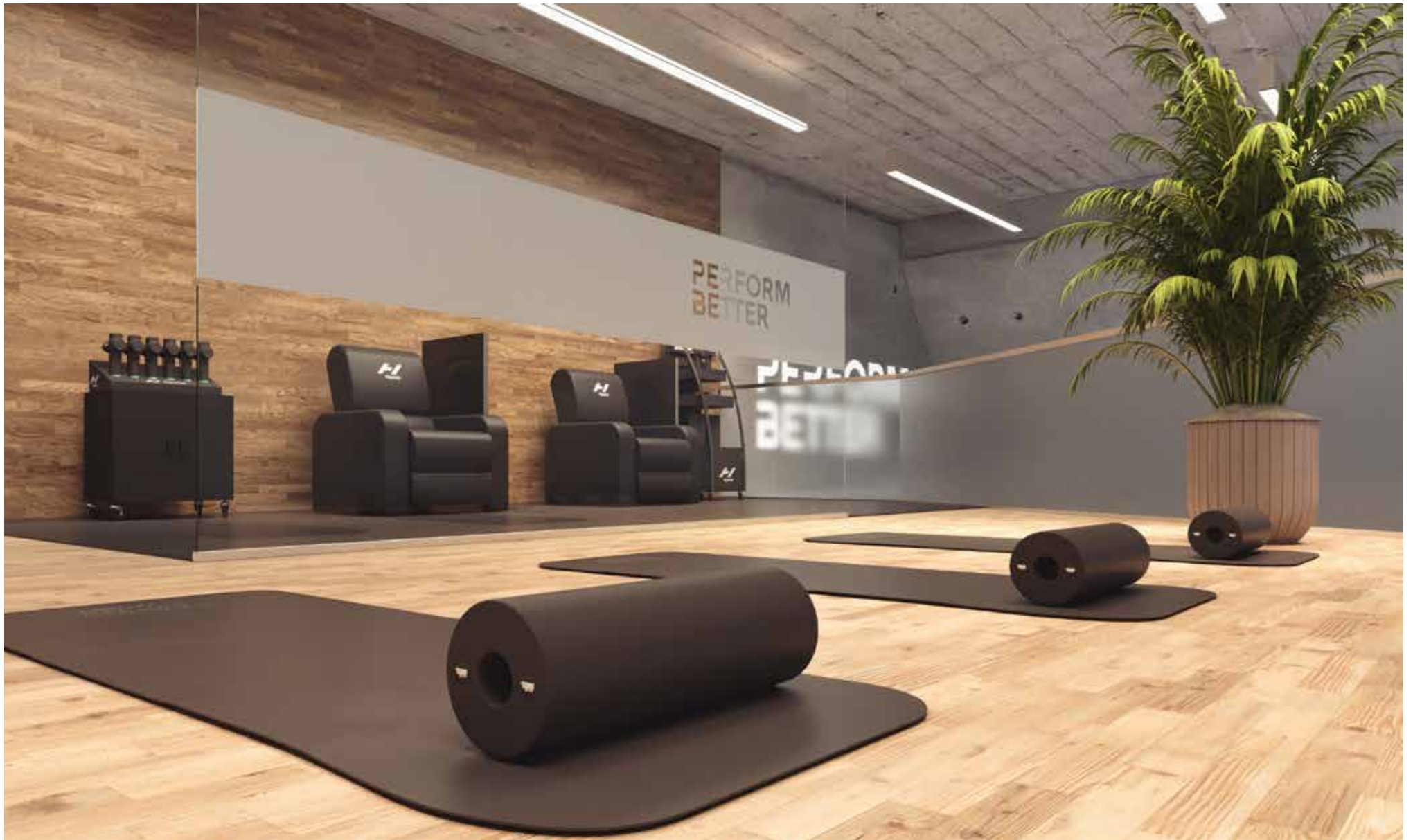

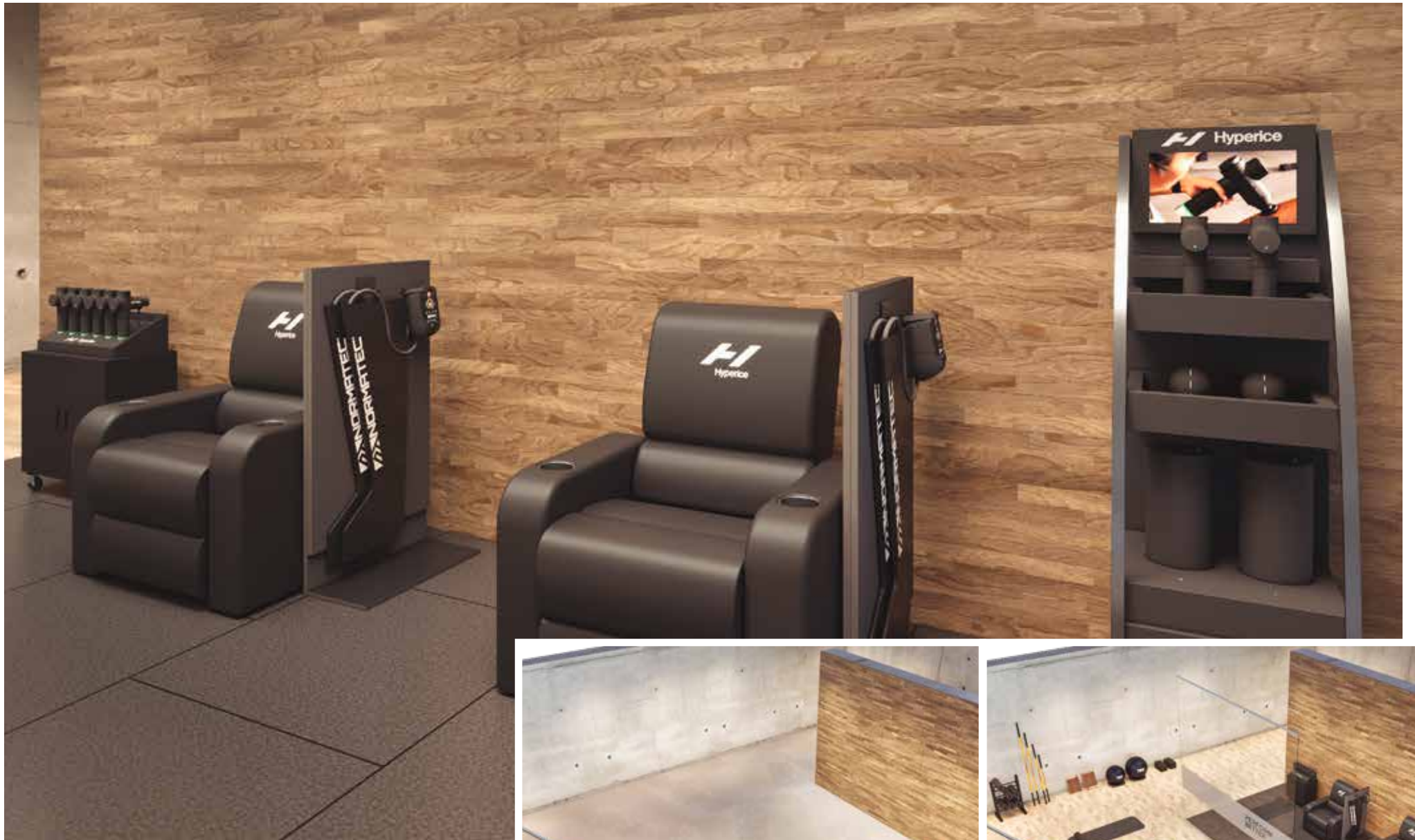

# PB Physio

## Individual solutions for you, your team and your patients!

We are aware that the needs and goals of your patients are extremely individual. That's why, with our many years of experience, we are ready to help you create the right ambience and select the right equipment. Whether it's a new design, a remodelling, a renovation or a modernization - we always offer the perfect room and furnishing concept.

Our expertise includes not only understanding what atmosphere makes patients feel comfortable, but also the needs you and your staff have for the medical practice rooms.

By optimizing your internal workflows and creating an attractive environment, we want to help not only support you and your employees, but also inspire your patients.

PERFORM  
BETTER

**PERFORM  
BETTER**



200 sqm

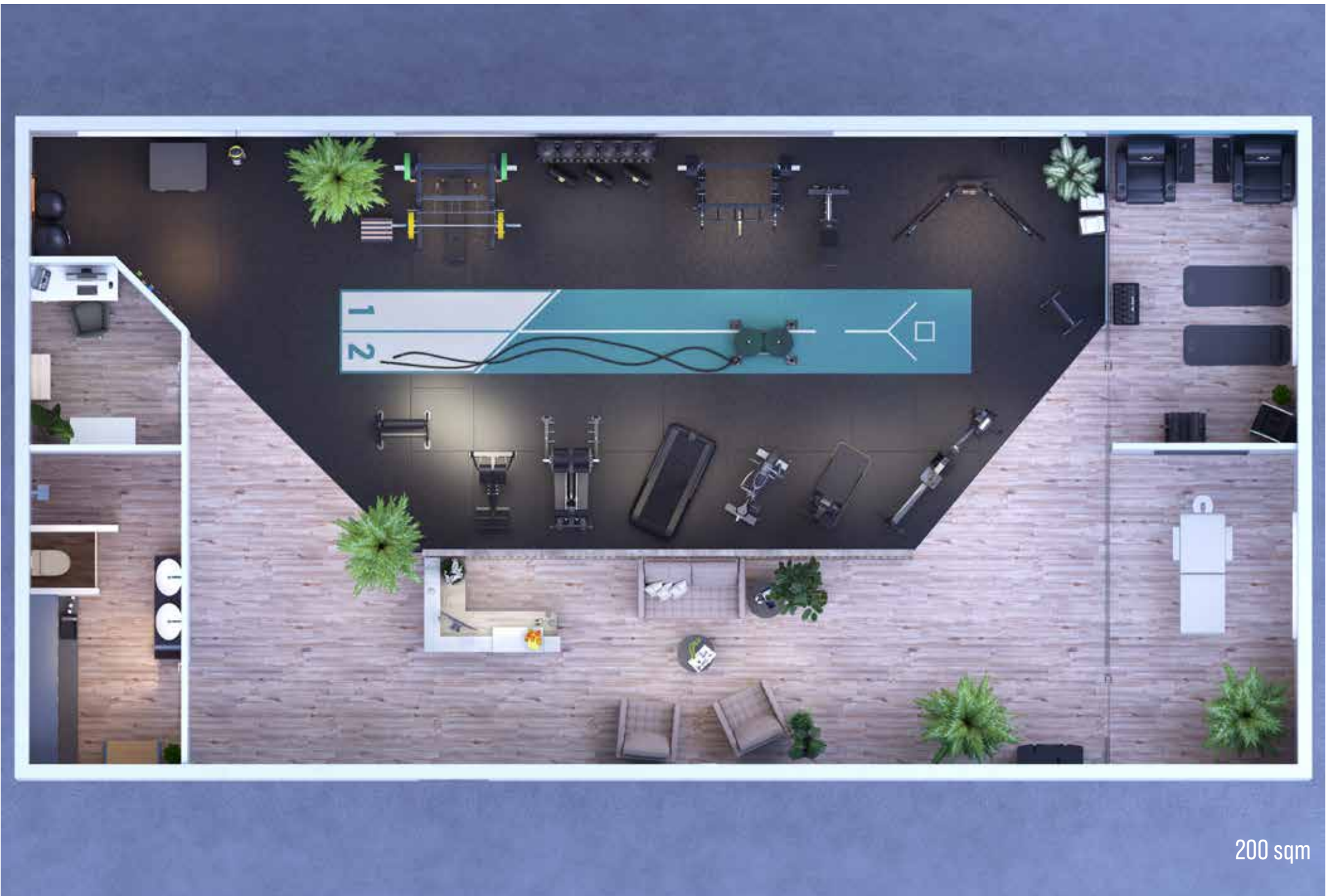

200 sqm



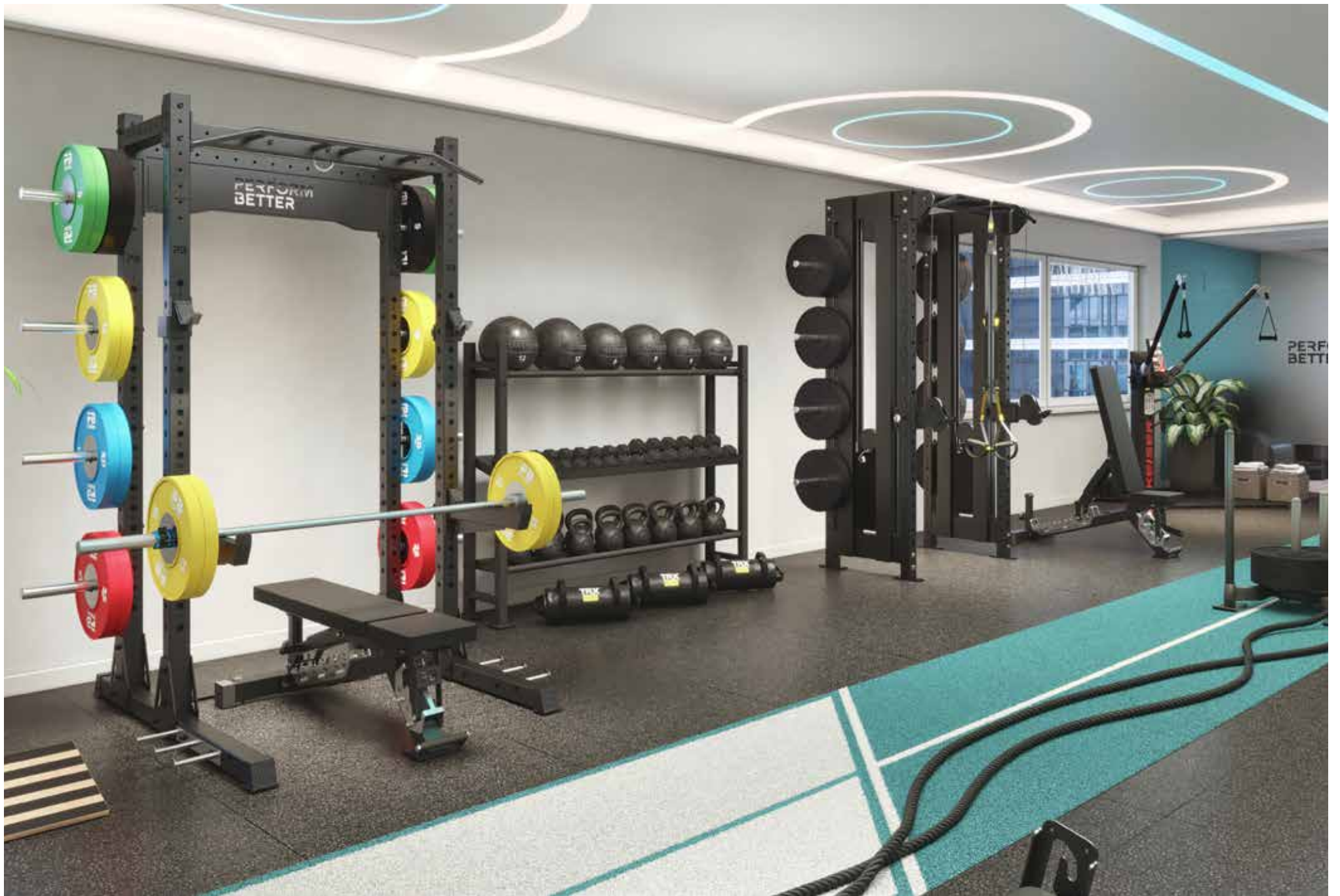













# TRX Studioline

Discover the opportunity to create a state-of-the-art training space that is perfectly designed for your needs with our innovative functional training room solutions. Our packages offer individual solutions for every setting, regardless of the size of your studio.

With TRX® studio solutions, you have the freedom to create a customized functional training zone with an attractive design and make the most of any available space. With our highly customizable anchoring and support systems, you can not only maximize space efficiency, but also take training functionality to the next level.

In addition, our products impress with their high-quality and robust manufacturing, which not only guarantees a long service life, but also creates an aesthetic atmosphere in any room. Discover the TRX® TRAINING ZONE and inspire your customers with a first-class training experience!



Check it out now





# TRX Training Zone<sup>®</sup> Solutions



TRX Bridge



TRX Bridge

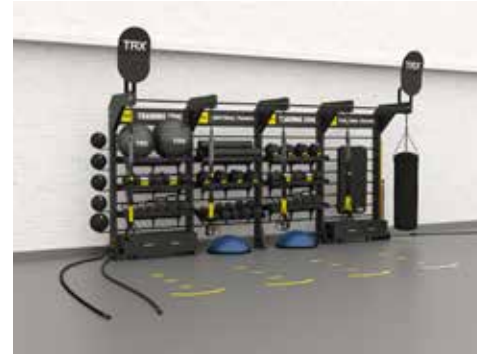

TRX Quad Bay



TRX Double Bay



TRX Corner



TRX T-Unit



TRX Bay & Strength Bay



TRX Single Post





# CENTR x HYROX

HYROX has established itself as the leading event in the functional training scene in recent years and has attracted a large community. However, to be successful in this challenge, not only effective training is important, but also the right equipment and the right setting.

This is where the new performance line from CENTR x HYROX comes into action. It not only offers a clean design, but also optimizes aerodynamics and performance. From power sleds with interlocking bumper plates to power ropes, wall balls and innovative kettlebells, each element is specifically designed for HYROX training or competition. This allows us to design not only HYROX areas, but also complete HYROX gyms that perfectly prepare your customers for their next challenge. Our gyms are hotspots for the community and unite people with the same passion and motivation. Join us and let us make your HYROX gym a reality!



 **CENTR**

**HYROX**





Competition Power Sled

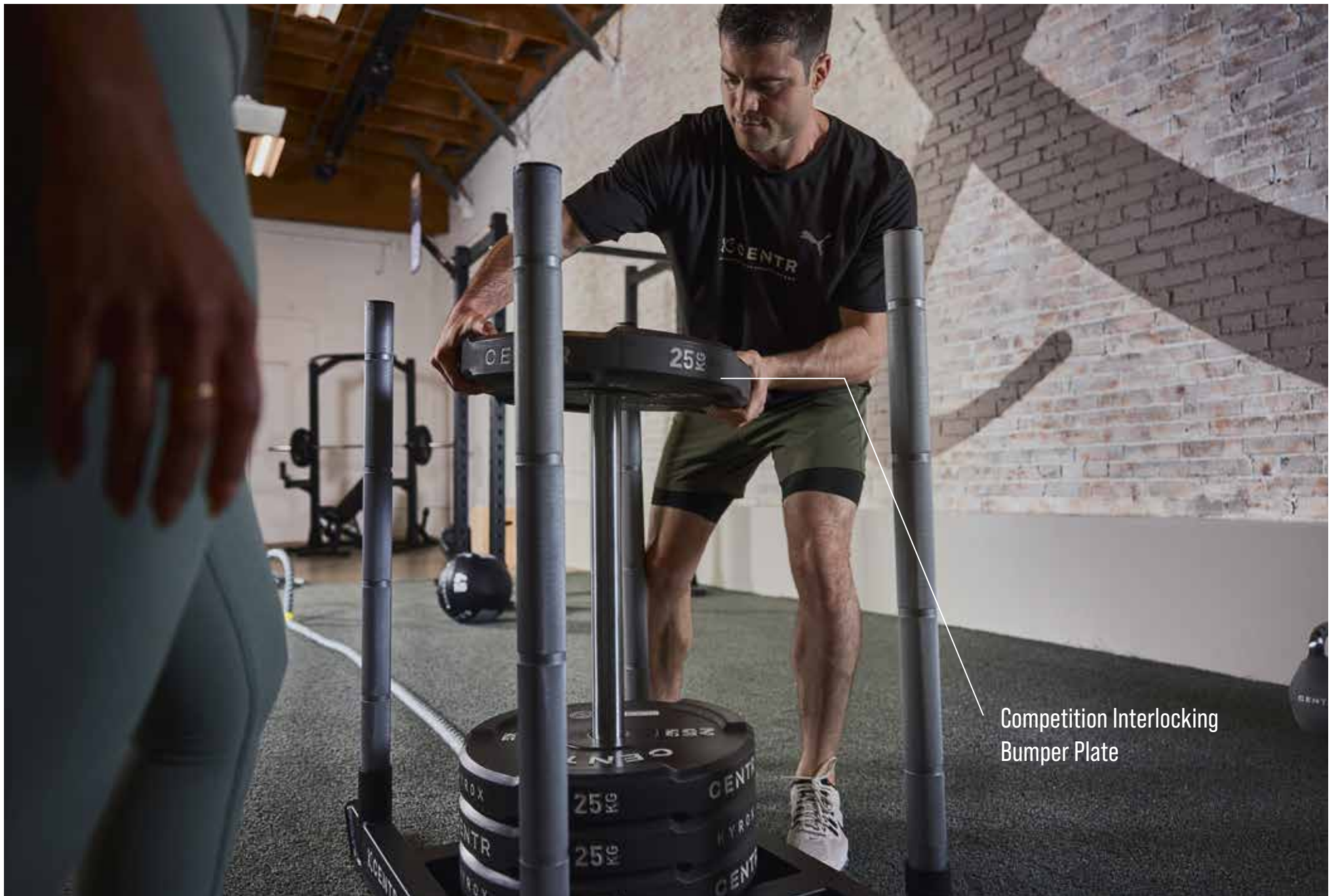

Competition Interlocking Bumper Plate



Competition  
Power Rope



Competition  
Sandbag



Competition  
Octo Kettlebell





Competition  
Rig Target

Competition  
Wall Ball

# PB

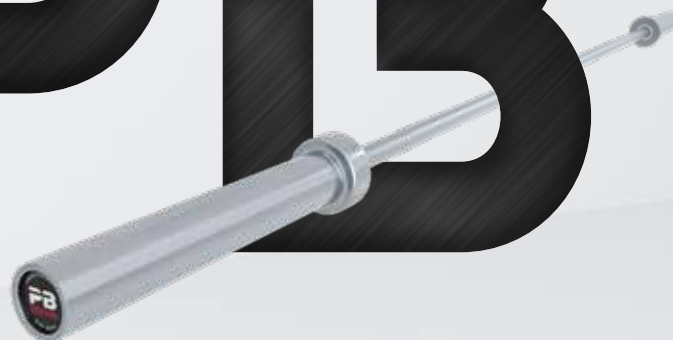

## PB Steel

Looking for a new centerpiece for your Functional Zone? Discover our high-quality steel products. Choose from a wide range of fully customizable rigs and racks, attachments and multistorage.

Whether for home gyms, fitness studios, performance centers or physiotherapy practices – our products offer almost endless customization options and impress with their robustness and premium quality.



PB Half Rack  
PB Dip Bar  
PB Safety Spotter  
PB Wall Ball Plate



PB Connector pull-up bar



PB Connector Multistorage



PB Pulley



PB Cable Pull Elite



PB Glute Ham Developer





PB Hyperextension



PB Glute Builder

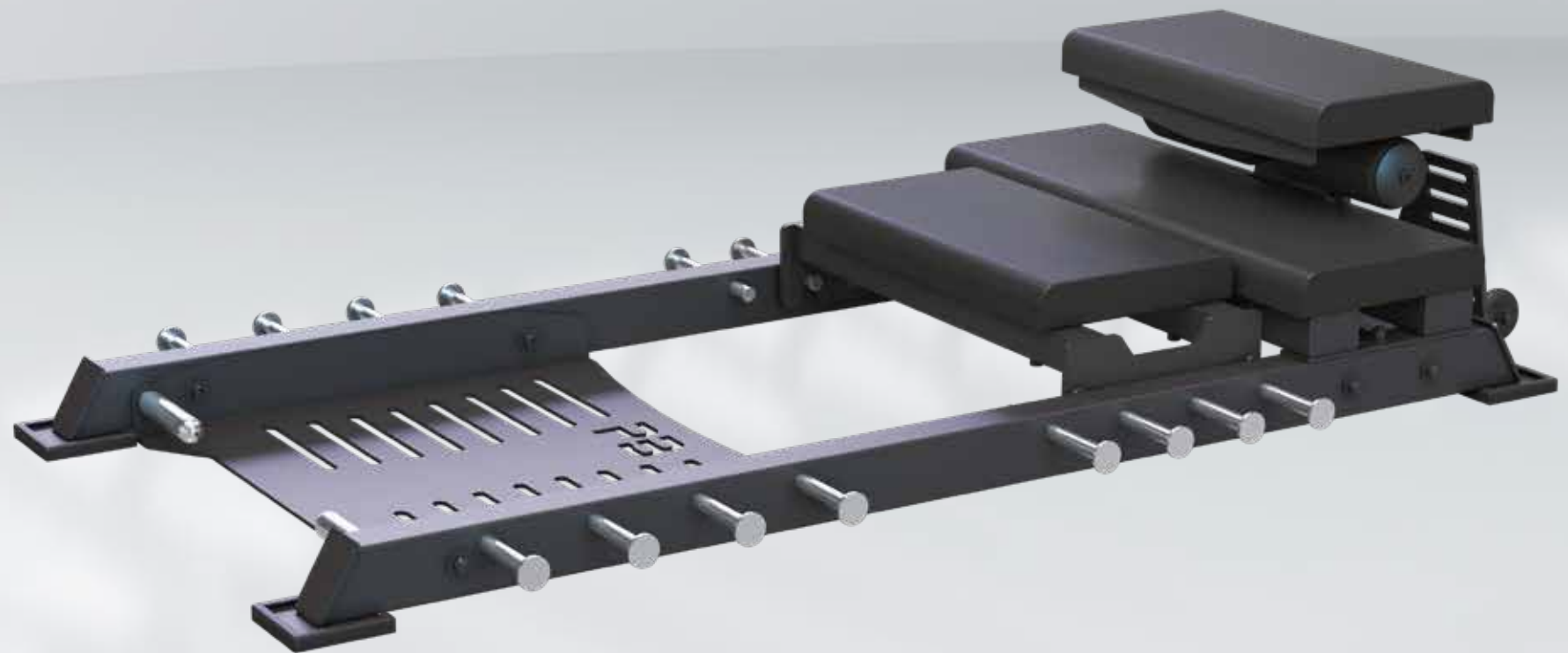

PB Hipthrust



PB Squat Rack  
PB Squat Stand



PB bench

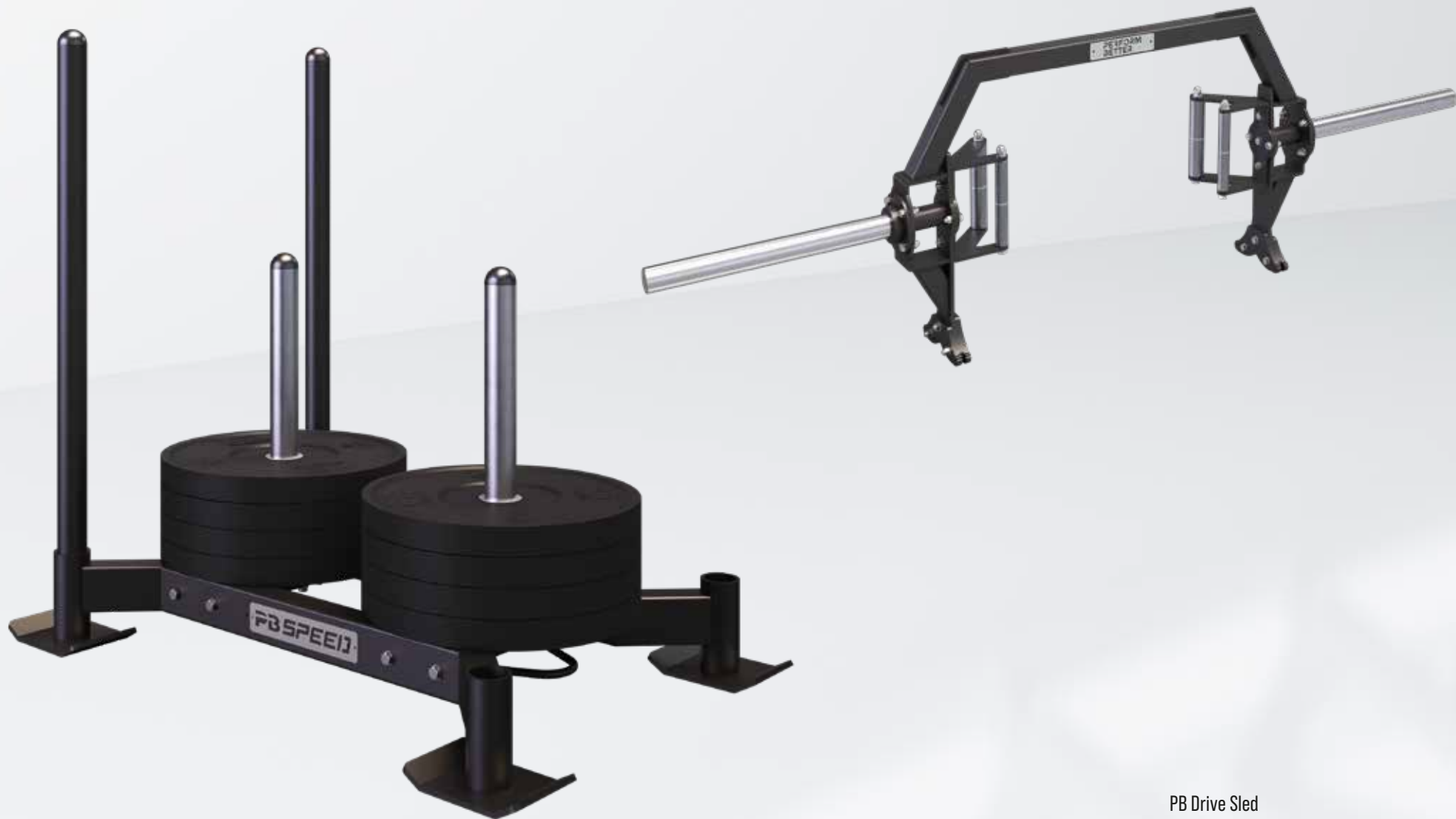

PB Drive Sled  
PB Combo Hexbar



PB Dumbbell Storage  
PB Multi Storage

# The right solution for everyone

We understand that every project is unique and therefore focus on individuality. Our goal is to design customized training environments that are perfectly designed for you and your clients - whether it's a gym, a physiotherapy practice, a personal training studio or an athletics center.

With over 10 years of experience and our profound expertise in functional and athletic training, we are ready to provide you with targeted support. From planning to installation, our solutions are customized to your exact needs and location. Together we will turn your vision into reality!







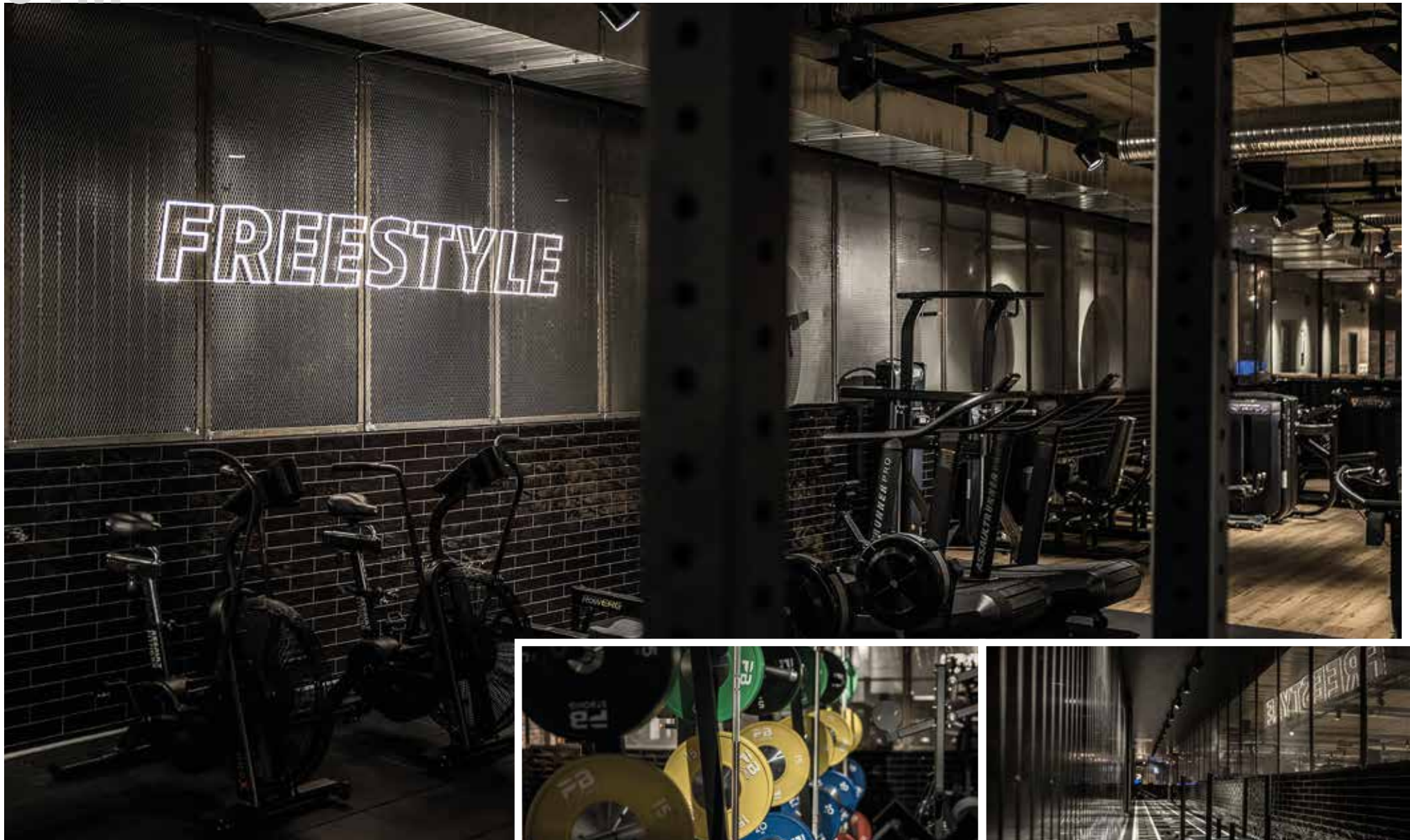

## Fitness First Wolfenbüttel

1.900 sqm



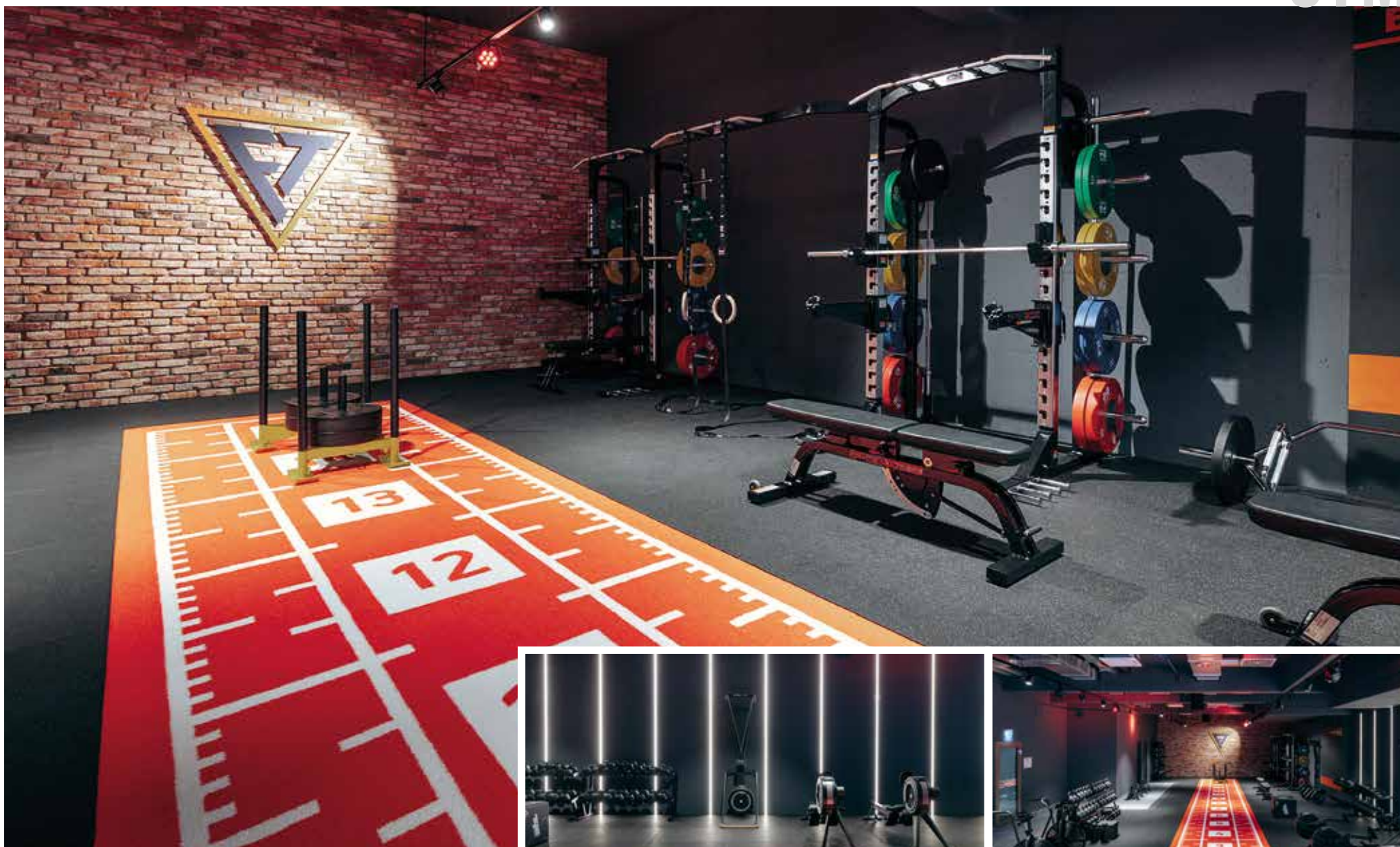

## FT-CLUB Stuttgart

200 sqm



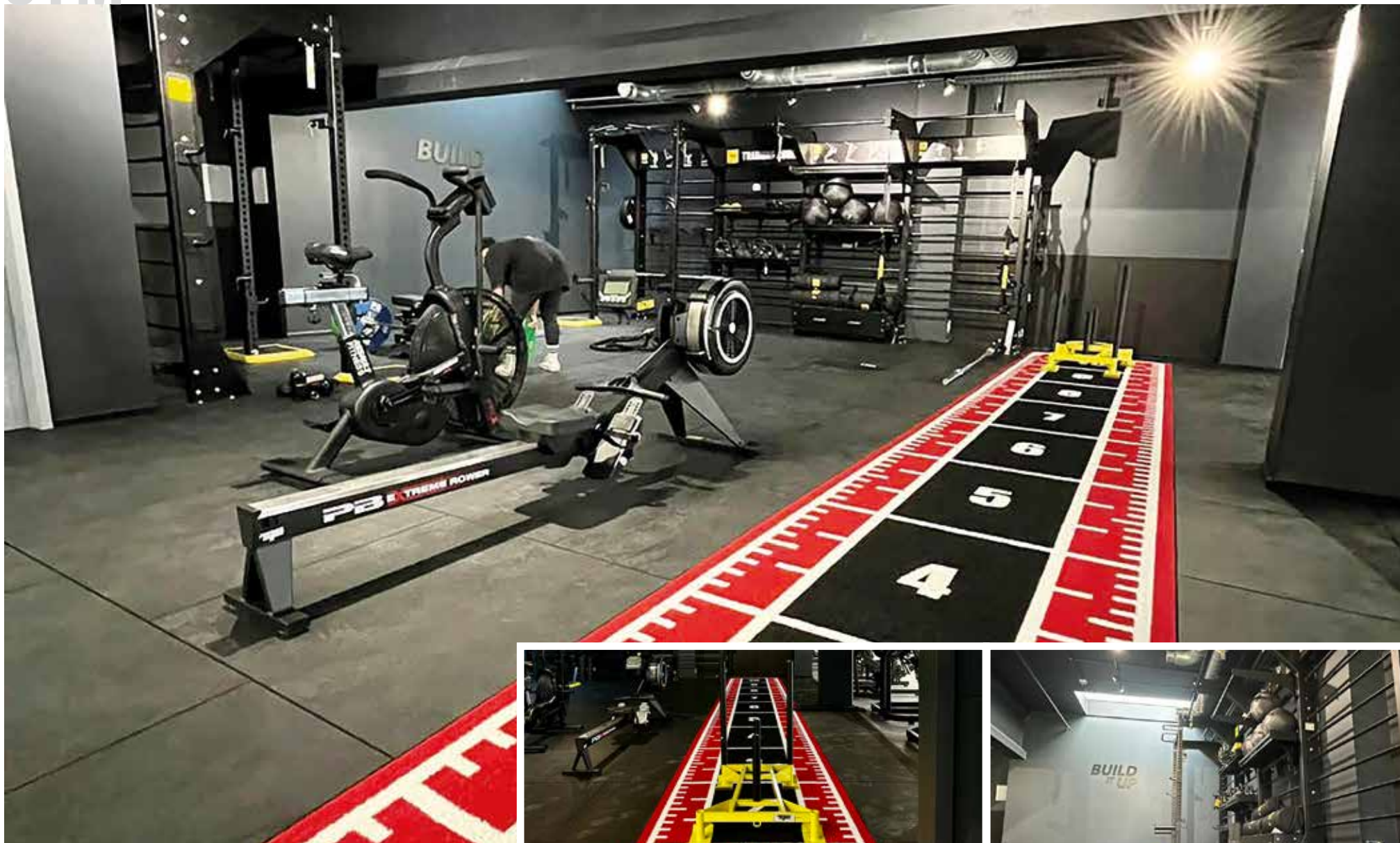

## Clever Fit Wasserburg

85 sqm

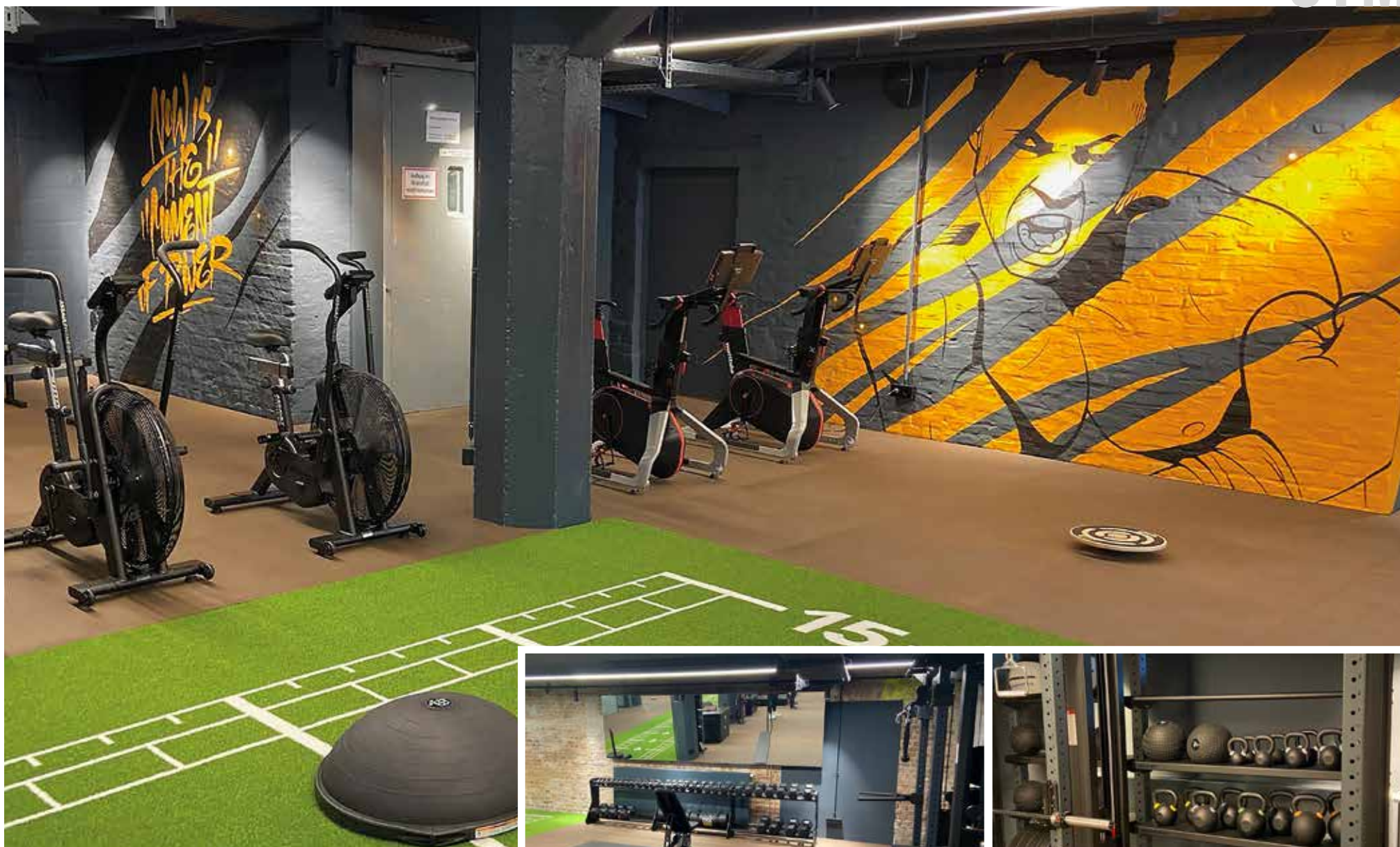

## Orangery

400 sqm





## BVB Dortmund

330 sqm



## Borussia Mönchengladbach

280 sqm



# PHYSIO

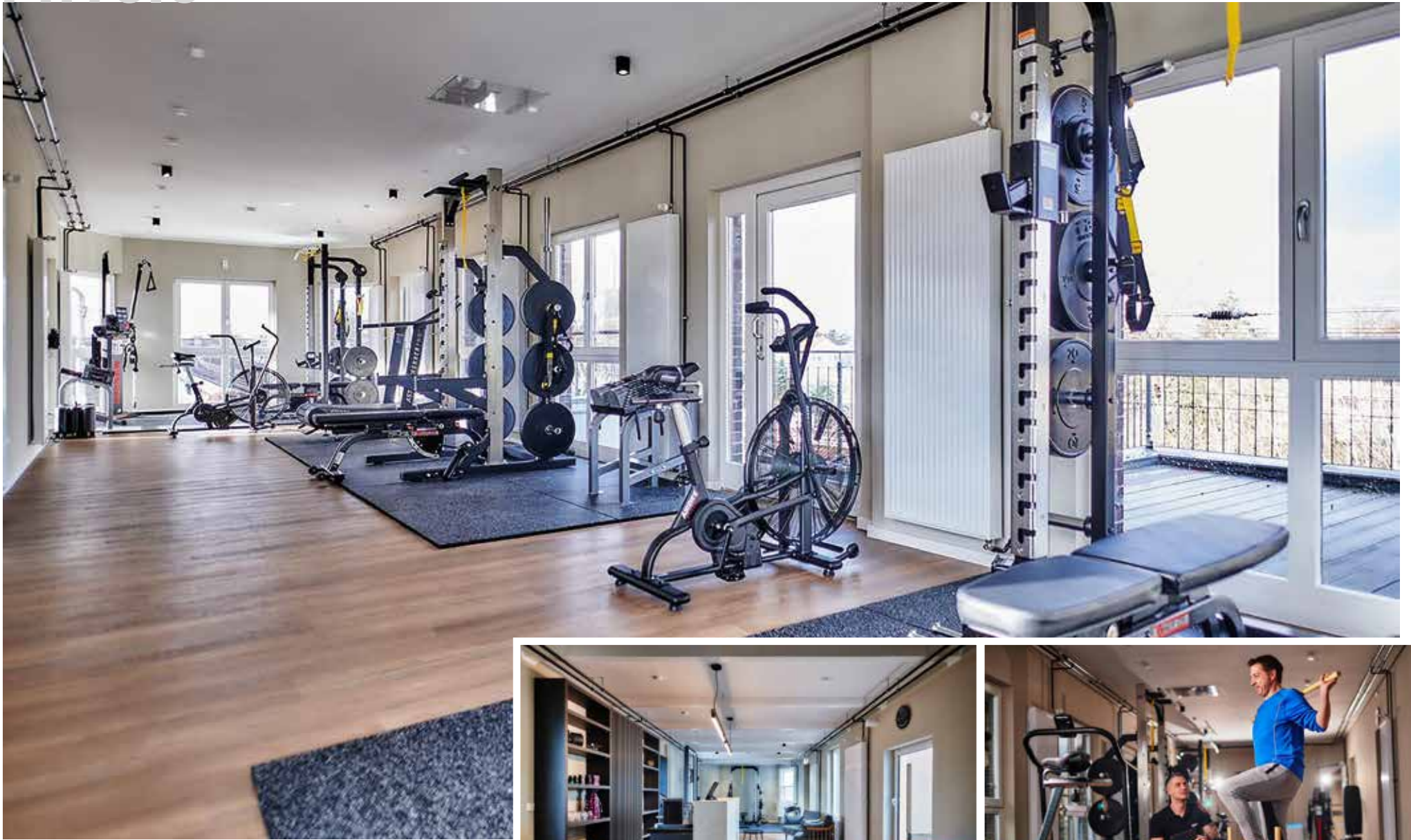

GRT

240 sqm

72







## T&T Therapie & Training

150 sqm



# PHYSIO



## Healthlab

130 sqm





## HYPERICE Recovery Areas



# OUTDOOR

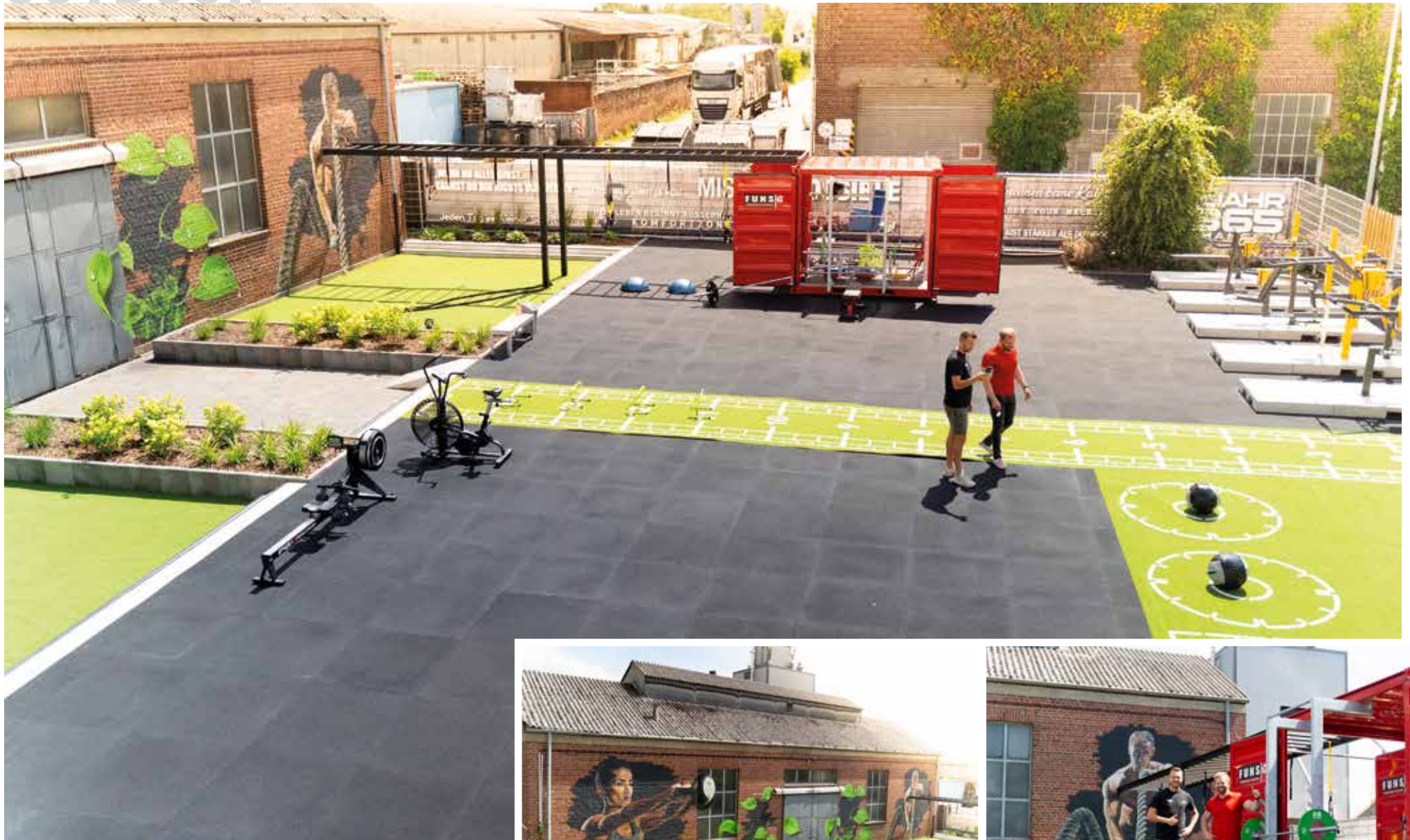

## Halle 22

650 sqm





## Merkur Gym- FUNS C

500 sqm



# PERSONAL TRAINING



## My Private Gym

85 sqm





## Homegym Steffi Marth

15 sqm

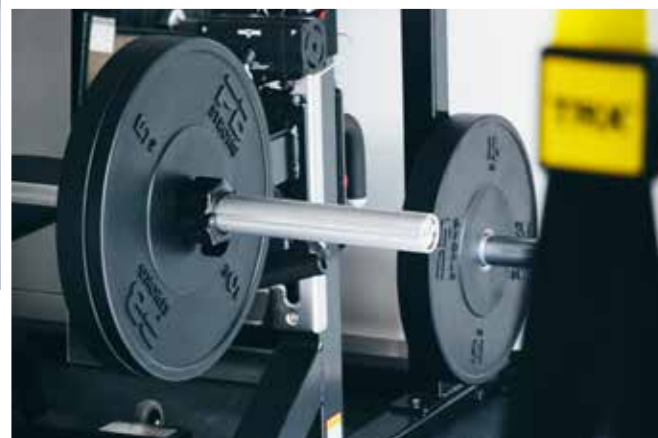

# COMPANY GYM

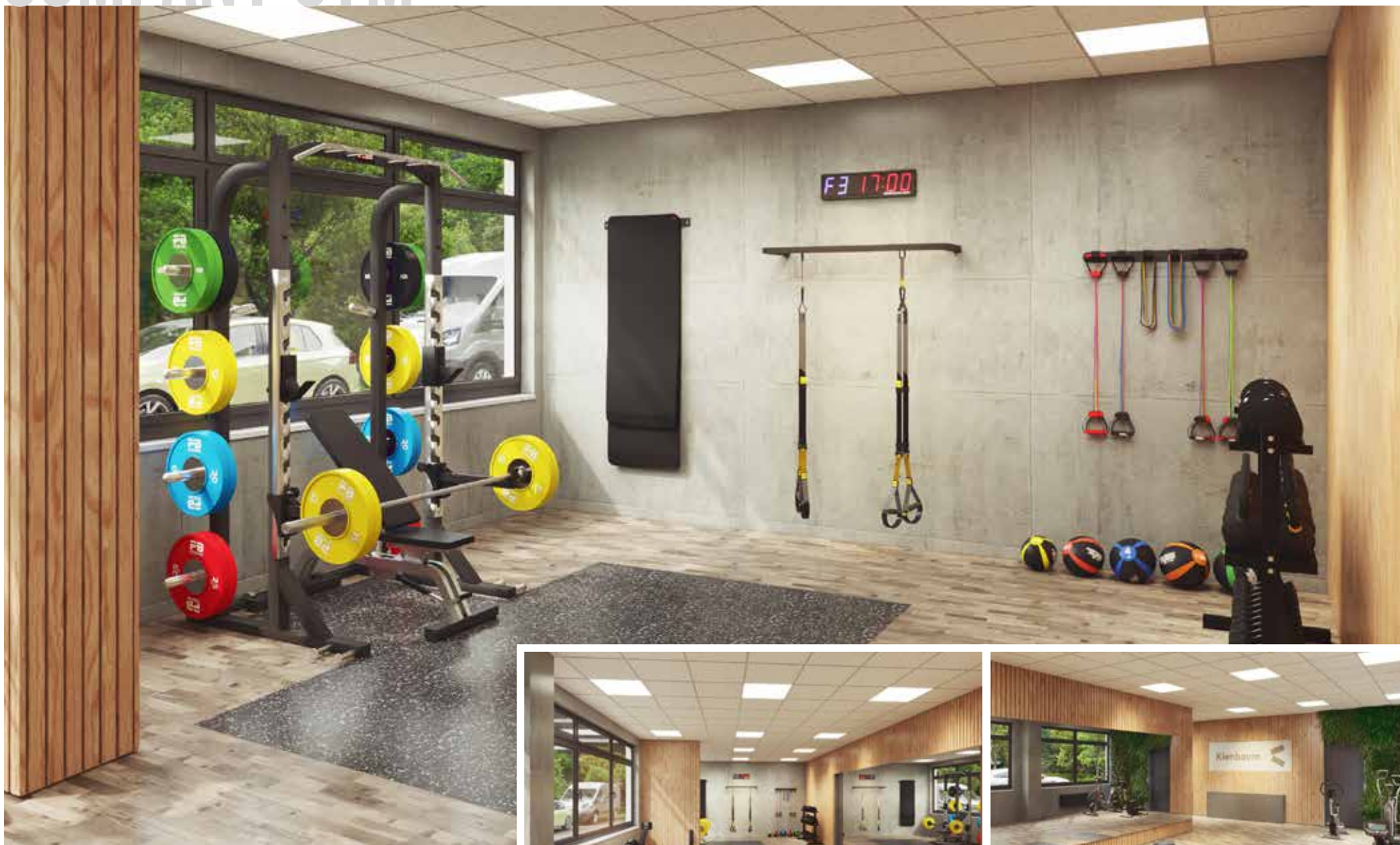

Kienbaum





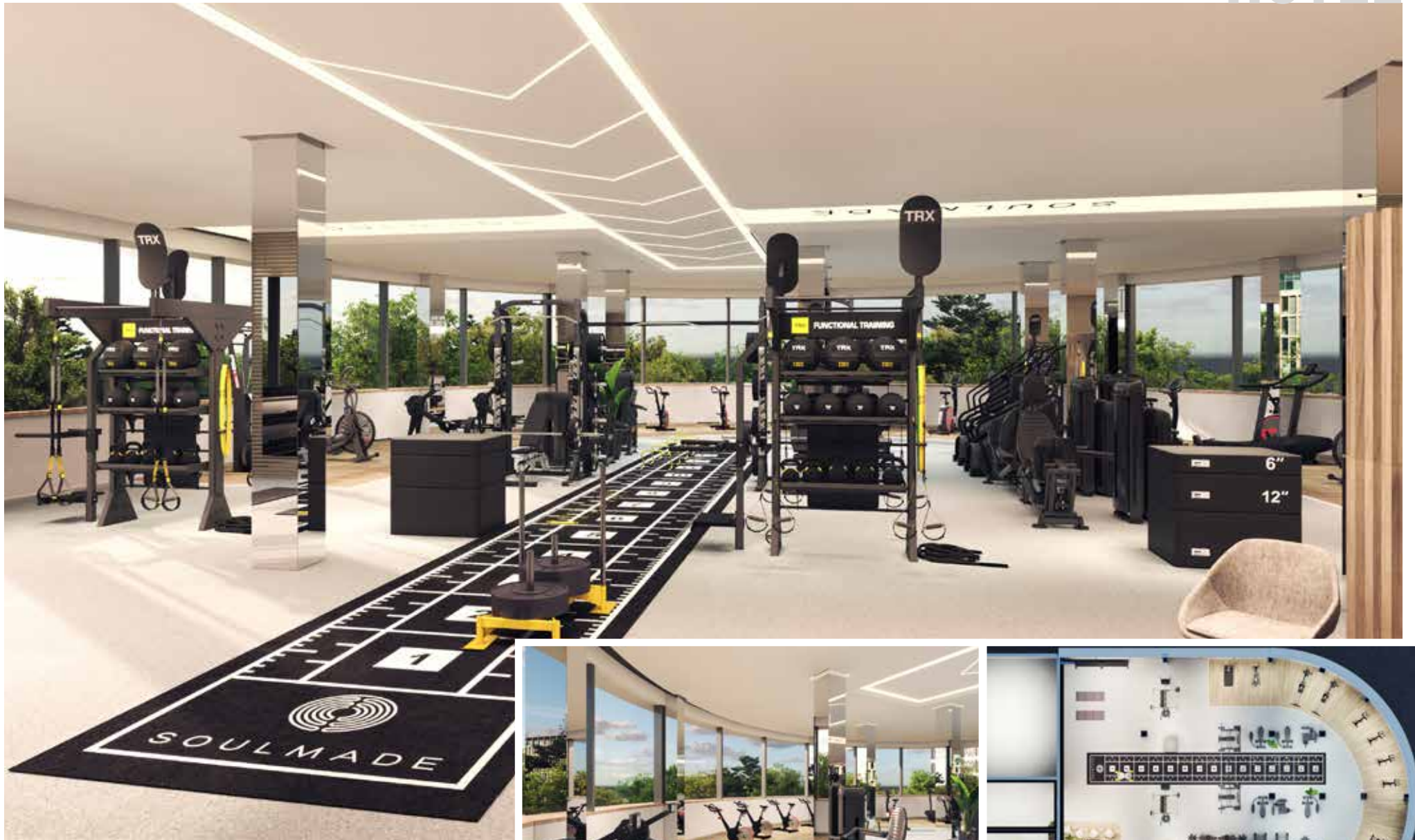

Hotel Helsinki



# In-house training

For you and your team: individual, cost-efficient and high-quality!

Optimize your expertise with customized in-house training. Our cost-effective and individual programs keep you and your team up-to-date in areas such as therapy, training and rehabilitation. With short travel times and no additional hotel costs, we guarantee the highest quality as our experienced instructors come directly to you. Trust in our many years of experience for the complete planning and implementation of your training. Increase the professionalism of your team and the quality of your institution!

Overall, lifelong learning is a crucial factor for personal and professional growth. Through in-house training, you can ensure that your employees in your studio/practice are continuously developing new skills and evolving to meet the demands of a changing world of work.

**+300.000**

Satisfied customers

**+10.500**

Qualified trainers

**+450**

In-house training

**PERFORM  
BETTER  
INSTITUTE**



## The benefits of your in-house training:

- Emotional connection to the team and their mission
- Shared know-how: manual & certificate for each participant
- You can train your entire team at the same time with one appointment
- Save travel costs for you and your team - we come to you
- Clear concepts that are easy to teach and manage
- Flexible scheduling - determine the time of the training yourself
- Individually customized to your wishes

## 5 steps to your in-house training course:

1

### Contact us

Get in touch with us by email at [seminare@perform-better.de](mailto:seminare@perform-better.de) or by phone on +49 89 4444679-251.

2

### Get to know us

We will get back to you immediately to discuss your wishes and the details.

3

### Feedback & detailed planning

We discuss your feedback on our offer and adapt it to your wishes.

4

### Finalization

We finalize the offer with all your wishes and plan a fixed date for the in-house training.

5

### Realization

The in-house training course takes place on your location at your preferred times and all participants receive a certificate of attendance.



Get a non-binding offer now



# Brands

With our expertise and passion, we help people to get fitter, stronger and healthier. To do this, we partner with leading international brands such as TRX, Hyperice and BlazePod. These partnerships enable us to provide customized equipment that meets the individual goals and needs of our customers. This enables us to provide them with targeted support on their path to success.







Wettkampf Langhantelstangen



Safety Squat Bar



Hantelstangen Zubehör



Wettkampf Hantelscheiben



Hantelscheibenset Gummi



3-Griff Hantelscheiben



Black Kettlebells



Hexhanteln



Neopren Kurzhanteln



Chrom Kurzhanteln





Soft Plyo Box



3-in-1 Soft Plyobox



Training Rope



Medizinball



Soft Medizinball



Jam Ball



SAQ Hürden 6er Set



Speed Rope



SAQ Ladder



Normatec 3 Leg Recovery System



Normatec Lower Legs



Hypervolt 2 Pro



Hypervolt Go 2



Hypervolt Wärme Aufsatz



Hypersphere Mini



Venom Go



Vyper 2.0



Vyper Go

# TRX®



TRX Suspension Trainer Studioversion 4.0

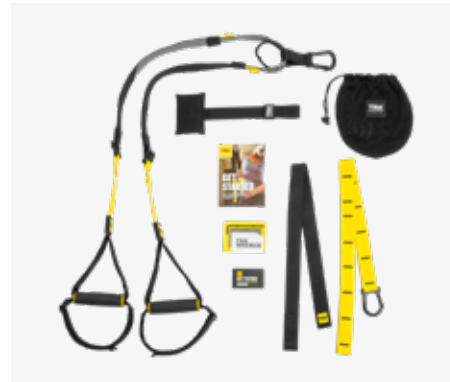

TRX Suspension Trainer Pro 4



TRX Force Kit



TRX Suspension Trainer Home 2



TRX RIP Trainer



TRX Bandit



TRX YBell Neo



TRX Kettlebells



TRX Slam Balls



TRX Weighted Belt



BlazePod Standard Kit



BlazePod Trainer Kit



BlazePod Pod Base

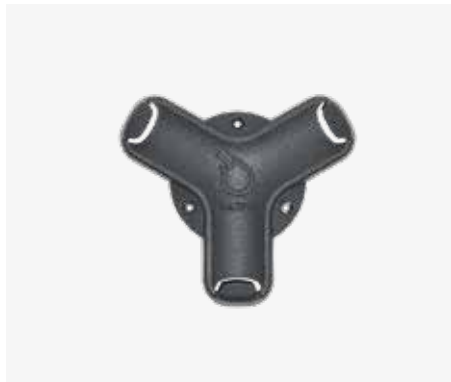

BlazePod Wall Mount Adaptor



BlazePod Cone Adapter Kit



BlazePod Functional Adapter Kit

**ASSAULT**FITNESS



Assault Air Bike Pro X



Assault Air Bike Classic



Assault AirRunner Pro SH



Competition Power Sled



Competition Interlocking Bumper Plate



Competition Power Rope



Competition Sandbags



Competition Octo Kettlebells



Competition Rig Target & Wall Ball



Mobility Stick



Mobility Stick Graphit



Keiser Functional Trainer



Keiser M3 i Indoor Cycle Lite Indoor Bike



FMS Test Kit

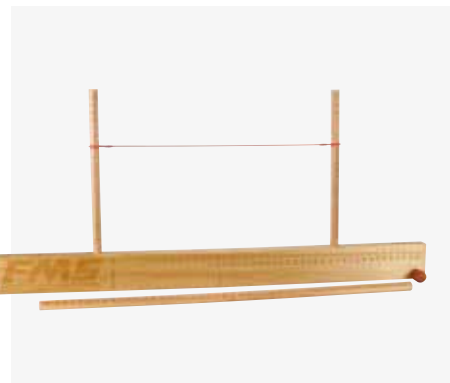

Professional FMS Test Kit



Y Balance Test Kit



Rudergerät



Ski Trainer



**Mükremin Bingöl**  
 Head of Sales | PLZ 6+7+8+9  
 International Sales Manager  
 +49 89 4444679-2632  
 +49 176 1791 32 47  
 mbingoel@perform-better.de



**Marcel John**  
 Sales Manager | PLZ 0+1+3  
 +49 89 5008079-16  
 +49 171 2631681  
 mjohn@perform-better.de



**Hannes Thies**  
 Clubs / Associations | PLZ 8+9  
 International Sales Manager  
 +49 89 4444679-168  
 hthies@perform-better.de



**Matthäus Lampl**  
 Sales Manager  
 Österreich (AT) & Schweiz (CH)  
 +43 (0) 676 55 62 760  
 mlampl@perform-better.de



**Daniel Fitschen**  
 Sales Manager | PLZ 2+4+5  
 Retail  
 +49 89 4444679-126  
 +49 171 6813755  
 dfitschen@perform-better.de



**Katharina Schwarcz**  
 Inhouse Schulungen  
 Perform Better Institute  
 +49 89 4444679-244  
 kschwarcz@perform-better.de



Inspired? Start now!

**PERFORM  
BETTER**